



## Starting Guide

Dedicated inverter for lift applications with induction motor in open loop

3 ph 400 VAC 4.0 – 15 kW

<b>Version</b>	<b>Changes applied</b>	<b>Date</b>	<b>Written</b>	<b>Checked</b>	<b>Approved</b>
1.0.0	First release	25.10.2019	J. Alonso		
1.0.1	Small text corrections	25.11.2019	J. Alonso	C. Arjona	J. Català
1.0.2	Chapter 7.1.4 correction Table and figure numbers correction	06.07.2020	C. Arjona	J. Alonso	J. Català
1.1.0	230V mode added Year of standards revised; RoHS 2 standard added Lift directive and notes on table 3.1 updated Section 5.1 title correction Table and figure numbers correction on chapter 5 Correction of parameter F21 on Figure 10.1 DBA alarm code added in chapter 13 Small text corrections	28.01.2021	C. Arjona	J. Alonso	J. Català

## CONTENTS

0.	About this manual .....	4
1.	Safety information .....	4
2.	Conformity to European standards .....	6
3.	Technical data .....	7
3.1	Specifications .....	7
3.2	Three-phase 230V mode specifications .....	8
3.3	External dimensions .....	9
4.	Removal and attachment of front cover .....	9
5.	Connections .....	10
5.1	Power terminals connection .....	10
5.2	Control signals connection .....	11
5.3	Use of input terminals for speed set point selection .....	11
5.4	Control terminals description .....	11
6.	Hardware configuration .....	14
7.	Keypad operation .....	15
7.1	TP-E1U (Basic keypad) .....	15
7.1.1	Led monitor, keys and LED indicators on the keypad .....	15
7.1.2	Overview of operation modes .....	16
7.1.3	USB connectivity .....	16
7.1.4	TP-E1U Menu .....	16
7.2	TP-A1-LM2 (Advanced keypad) .....	18
7.2.1	Keypad keys .....	18
7.2.2	Keypad menus .....	19
7.2.3	Example of function setting .....	20
7.2.4	Display language setting .....	20
8.	Driving the motor .....	21
8.1	Inverter initialization .....	21
8.2	Specific setting .....	21
8.3	Auto tuning procedure .....	21
9.	Setting the speed profile .....	22
10.	Signal time diagram for open loop (IM) .....	23
11.	Travel optimization .....	24
12.	Lift fine tuning (troubleshooting) .....	25
13.	Alarm messages .....	26



## 0. About this manual

Thank you very much for choosing FRENIC-Lift (LM2) inverter series.

FRENIC-Lift (LM2) inverter series are specially designed for operation of induction motors used in lift applications. Induction motors without encoder (open loop) can be controlled obtaining good performance and high positioning accuracy at stop.

This starting guide includes the basic information and explanations about the connection and commissioning of FRENIC-Lift LM2C.

 This starting guide is based on firmware version 1500 or later. For other software versions, please contact with Fuji Electric technical department.



Firmware version (ROM) can be monitored on TP-E1U in  (with E52=2) and on TP-A1-LM2 in   

For extended information about the product and its use, refer to below mentioned documents:

- FRENIC-Lift Reference Manual INR-SI47-1909\_-E (RM).
- FRENIC-Lift Instruction Manual INR-SI47-2224\_-E (IM).

## 1. Safety information

Read this manual thoroughly before proceeding with installation, connections (wiring), operation, or maintenance and inspection. Ensure you have enough knowledge of the device and familiarize yourself with all safety information and precautions before proceeding to operate the inverter. Safety precautions are classified into the following two categories in this manual.



 <b>WARNING</b>	Failure to heed the information indicated by this symbol may lead to dangerous conditions, possibly resulting in death or serious bodily injuries.
 <b>CAUTION</b>	Failure to heed the information indicated by this symbol may lead to dangerous conditions, possibly resulting in minor or light bodily injuries and/or substantial property damage.

**Failure to heed the information contained under the CAUTION title can also result in serious consequences. These safety precautions are importance and must be observed at all times.**

### Application

 <b>WARNING</b>
<ul style="list-style-type: none"><li>• FRENIC-Lift is designed to drive a three-phase motor. Do not use it for single-phase motors or for other purposes. <b>Fire or an accident could occur.</b></li><li>• FRENIC-Lift may not be used for a life-support system or other purposes directly related to the human safety.</li><li>• Though FRENIC-Lift is manufactured under strict quality control, install safety devices for applications where serious accidents or material losses are foreseen in relation to the failure of it. <b>An accident could occur.</b></li></ul>

### Installation

 <b>WARNING</b>
<ul style="list-style-type: none"><li>• Install the inverter on a non-flammable material such as metal. <b>Otherwise fire could occur.</b></li><li>• Do not place flammable object nearby. <b>Doing so could cause fire.</b></li></ul>
 <b>CAUTION</b>
<ul style="list-style-type: none"><li>• Do not carry the inverter by its terminal block cover during transportation. <b>Doing so could cause a drop of the inverter and injuries.</b></li><li>• Prevent lint, paper fibres, sawdust, dust, metallic chips, or other foreign materials from getting into the inverter or from accumulating on the heat sink. <b>Otherwise, a fire or an accident might result.</b></li><li>• Do not install or operate an inverter that is damaged or lacking parts. <b>Doing so could cause fire, an accident or injuries.</b></li><li>• Do not stand on a shipping box.</li><li>• Do not stack shipping boxes higher than the indicated information printed on those boxes. <b>Doing so could cause injuries.</b></li></ul>

## Wiring

### **WARNING**

- When wiring the inverter to the power supply, insert an appropriate mains disconnecting device (e.g. switch, contactor, breaker etc.) Use the devices within the recommended current range.
- Use wires size recommended in Instruction Manual.
- When wiring the inverter to the power supply that is 500 kVA or more, be sure to connect an optional DC reactor (DCR).  
**Otherwise, fire could occur.**
- Do not connect a surge killer to the inverter's output (secondary) circuit.  
**Doing so could cause fire.**
- Ground the inverter in compliance with the national or local electric standards.  
**Otherwise, electric shock could occur.**
- Qualified electricians should carry out wiring.
- Disconnect power before wiring.  
**Otherwise, electric shock could occur.**
- Install inverter before wiring.  
**Otherwise, electric shock or injuries could occur.**
- Ensure that the number of input phases and the rated voltage of the product match the number of phases and the voltage of the AC power supply to which the product is to be connected.  
**Otherwise fire or an accident could occur.**
- Do not connect the power supply wires to output terminals (U, V, and W).
- Connect the braking resistor only to the terminals DB and P(+).  
**Otherwise, fire could occur.**
- Generally, control signal wires are not reinforced insulation. If they accidentally touch any of live parts in the main circuit, their insulation coat may break for any reasons. In such a case, ensure the signal control wire is protected from making contact with any high voltage cables.  
**Doing so could cause an accident or electric shock.**

### **CAUTION**

- Connect the three-phase motor to terminals U, V, and W of the inverter.  
**Otherwise injuries could occur.**
- The inverter, motor and wiring generate electric noise. Ensure preventative measures are taken to protect sensors and sensitive devices from RF noise.  
**Otherwise an accident could occur.**

## Operation

### **WARNING**

- Be sure to install the terminal cover before turning the power ON. Do not remove the covers while power is applied.  
**Otherwise electric shock could occur.**
- Do not operate switches with wet hands.  
**Doing so could cause electric shock.**
- If the auto-reset function has been selected, the inverter may automatically restart and drive the motor depending on the cause of tripping.  
(Design the machinery or equipment so that human safety is ensured after restarting.)
- If an alarm reset is made with the Run command signal turned ON, the inverter may start immediately. Ensure that the Run command signal is turned OFF in advance.  
**Otherwise an accident could occur.**
- Ensure you have read and understood the manual before programming the inverter, incorrect parameter settings may cause damage to the motor or machinery.  
**An accident or injuries could occur.**
- Do not touch the inverter terminals while the power is applied to the inverter even if the inverter is in stop mode.  
**Doing so could cause electric shock.**

## CAUTION

- Do not turn the main circuit power (circuit breaker) ON or OFF in order to start or stop inverter operation.  
**Doing so could cause failure.**
- Do not touch the heat sink and braking resistor because they become very hot.  
**Doing so could cause burns.**
- Before setting the speeds (frequency) of the inverter, check the specifications of the machinery.
- The brake function of the inverter does not provide mechanical holding means.  
**Injuries could occur.**

### Maintenance and inspection, and parts replacement

## WARNING

- Turn the power OFF and wait for at least five minutes before starting inspection. Further, check that the LED monitor is unlit and that the DC link bus voltage between the P (+) and N (-) terminals is lower than 25 VDC.  
**Otherwise, electric shock could occur.**
- Maintenance, inspection, and parts replacement should be made only by qualified persons.
- Take off the watch, rings and other metallic objects before starting work.
- Use insulated tools.  
**Otherwise, electric shock or injuries could occur.**

### Disposal

## CAUTION

- Treat the inverter as an industrial waste when disposing of it.  
**Otherwise injuries could occur.**

### Others

## WARNING

- Never attempt to modify the inverter.  
**Doing so could cause electric shock or injuries.**

## 2. Conformity to European standards

The CE marking on Fuji Electric products indicates that they comply with the essential requirements of the Electromagnetic Compatibility (EMC) Directive 2014/30/EU and the Low Voltage Directive 2014/35/EU issued by the Council of the European Communities.

Inverters with built-in EMC filter that bear a CE marking are in conformity with EMC directives. Inverters having no built-in EMC filter can be in conformity with EMC directives if an optional EMC compliant filter is connected to them. General purpose inverters are subject to the regulations set forth by the Low Voltage Directive in the EU. Fuji Electric declares the inverters bearing a CE marking are compliant with the Low Voltage Directive.

FRENIC-Lift (LM2) inverter series are in accordance with the regulations of following council directives and their amendments:

- Electromagnetic Compatibility Directive: 2014/30/EU
- Low Voltage Directive: 2014/35/EU
- Machine Directive: 2006/42/EC
- RoHS 2 Directive: 2011/65/EU

For assessment of conformity, the following relevant standards have been taken into consideration:

- EMC: EN61800-3:2018, EN12015:2014, EN12016:2013.
- Electrical Safety: EN61800-5-1:2007/A1:2017.
- Functional Safety: EN61800-5-2:2017 SIL3, EN ISO13849-1:2015 PLe, Cat.3 Safe Torque Off. Pollution degree 3.
- RoHS 2: EN50581:2012, EN IEC63000:2018.

## CAUTION

The FRENIC-Lift (LM2) inverter series are categorized as category C2 or C3 according to EN61800-3:2018. When you use these products in the domestic environment, you may need to take appropriate countermeasures to reduce or eliminate any noise emitted from these products.

### 3. Technical data

#### 3.1 Specifications

Table 3.1. FRENIC-Lift LM2C General specifications.

Item		Specifications						
Type FRN LM2C-4E		0010	0015	0019	0025	0032		
Nominal applied motor [kW]		4.0	5.5	7.5	11	15		
Output ratings	Rated capacity <sup>1</sup> [kVA]	7.6	11	14	18	24		
	Rated voltage <sup>2</sup> [V]	3-phase 480 to 480 VAC						
	Rated current <sup>3</sup> [A]	10.0	15.0	18.5	21.4 (24.5) <sup>8</sup>	32.0		
	Overload capacity [A] (Permissible overload time)	18.0 (3)	27.0 (3)	33.3 (3)	44.1 (3)	57.6 (3)		
Input ratings	Main power supply	Normal	3-ph 380 to 480 VAC, 50/60 Hz Variations: Voltage: +10 to -15% (Voltage unbalance: 2% or less <sup>4</sup> ), Frequency: +5 to -5%					
			Rated current <sup>5</sup> [A]	With DCR	7.5	10.6	14.4	21.1
			Without DCR	13.0	17.3	23.2	33.0	43.8
		Required power supply capacity (with DCR) [kVA]	5.2	7.4	10.0	15.0	20.0	
	UPS	1-ph 220 to 480 VAC, 50/60 Hz Variations: Voltage: +10 to -10%, Frequency: +5 to -5%						
		Input power for driving phases, voltage, frequency						
		Operation time [s]	180					
	Battery	Input power for driving voltage	48 VDC					
		Operation time [s]	180					
	Aux. control power voltage		24 VDC (22 to 32 VDC), max. 40 W					
Braking	Braking time <sup>7</sup> [s]		60					
	Braking duty-cycle (%ED) <sup>7</sup> [%]		50					
	Rated regenerative power <sup>7</sup> [kW]		3.2	4.4	6.0	8.8	12.0	
	Minimum resistance <sup>8</sup> [Ω]		96	47	47	24	24	
Conformity standard		<p><b>Lift Directive</b></p> <ul style="list-style-type: none"> <li>- Replacement of two motor contactors: interrupting the current to the motor (to stop the machine), as required by EN 81-20:2014 5.9.2.5.4 d &amp; 5.9.3.4.2 d</li> <li>- Brake monitoring for EN81-20:2014 5.6.7.3</li> </ul> <p><b>Machinery Directive</b></p> <ul style="list-style-type: none"> <li>- EN ISO13849-1: PL-e</li> <li>- EN60204-1: stop category 0</li> <li>- EN61800-5-2: STO SIL3</li> <li>- EN62061: SIL3</li> </ul> <p><b>Low Voltage Directive</b></p> <ul style="list-style-type: none"> <li>- EN61800-5-1: Over voltage category 3</li> </ul> <p><b>EMC Directive</b></p> <ul style="list-style-type: none"> <li>- with external EMC filter EN12015, EN12016, EN 61800-3 +A1, EN 61326-3-1 (Emission): Category 2 (0025 (11kW) or lower) / Category 3 (0032 (15kW) or higher) (Immunity): 2nd Env.</li> </ul> <p><b>Canadian and U.S. standards</b></p> <ul style="list-style-type: none"> <li>- Can/CSA C22.2 No.14-13: Industrial Control Equipment</li> <li>- CSA C22.2 No.274-13: Adjustable speed drives</li> <li>- UL 508 C (3rd Edition): Power Conversion Equipment</li> <li>- According to CSA B44.1-11/ASME A17.5-2014: Elevator and escalator electrical equipment</li> </ul>						
Enclosure (IEC60529)	Main body	IP20						
	Heat sink	IP54						
Cooling method		Fan cooling						

\*1) Rated capacity is calculated by regarding the output rated voltage as 440 VAC.

\*2) Output voltage cannot exceed the power supply voltage.

\*3) These values correspond to the following conditions: carrier frequency is 8 kHz (2 phase modulation) and ambient temperature is 45°C. Select the inverter capacity such that the square average current during operation is not higher than the 80% of the rated current of the inverter.

\*4) Voltage unbalance [%] = (Max.voltage [V] - Min.voltage [V]) / Three-phase average voltage [V] x 6 (IEC61800-3).

\*5) The power supply capacity is 500kVA (ten times the inverter capacity when the inverter capacity exceeds 50kVA), and the value of the power supply impedance is %X=5%.

\*6) The admissible error of minimum resistance is ±5%.

\*7) Braking time and duty cycle (%ED) are defined by cycle operation at the rated regenerative power.

\*8) Rated current is for 45°C, rated current in brackets corresponds to ambient temperature of 40°C.

### 3.2 Three-phase 230V mode specifications

Table 3.2. 3ph 230V mode specifications<sup>\*9</sup>

Item		Specifications					
Type FRN	LM2A-4E	0015	0019	0025	0032		
Nominal applied motor [kW]		3.0	4.0	5.5	7.5		
Output ratings	Rated capacity <sup>*1</sup> [kVA]	6.0	7.4	9.8	12.7		
	Rated voltage <sup>*2</sup> [V]	3-phase 220 to 230 VAC					
	Rated current <sup>*3</sup> [A]	15.0	18.5	21.4 (24.5) <sup>*8</sup>	32.0		
	Overload capacity [A] (Permissible overload time)	27.0 (3s)	33.3 (3s)	44.1 (3s)	57.6 (3s)		
Input ratings	Main power supply	Normal	Phases, voltage, frequency	3-ph 230 VAC, 50/60 Hz Variations: Voltage: +10 to -10% (Voltage unbalance: 2% or less <sup>*4</sup> ), Frequency: +5 to -5%			
			Rated Current <sup>*5</sup> [A]	With DCR	10.6	14.4	21.1
		Without DCR		17.3	23.2	31.5	42.7
		Required power supply capacity (with DCR) [kVA]	4.2	5.7	8.4	11.5	
	UPS	Input power for driving phases, voltage, frequency	1-ph, 220 to 240 VAC, 50/60 Hz Variations: Voltage: +10 to -10%, Frequency: +5 to -5%				
		Operation time [s]	180				
	Battery	Input power for driving voltage	DC 48V or more in the direct current voltage conversion.				
		Operation time [s]	180				
	Aux. control power voltage		24 VDC (22 to 32 VDC), max. 40 W <sup>*10</sup>				
	Braking	Braking time <sup>*7</sup> [s]		60			
Braking duty-cycle (%ED) <sup>*7</sup> [%]		50					
Rated regenerative power <sup>*7</sup> [kW]		2.4	3.2	4.4	6.0		
Minimum resistance <sup>*6</sup> [Ω]		24	24	16	12		
Conformity standard		<p><b>Lift Directive</b></p> <ul style="list-style-type: none"> <li>- Replacement of two motor contactors: interrupting the current to the motor (to stop the machine), as required by EN 81-20:2014 5.9.2.5.4 d &amp; 5.9.3.4.2 d</li> <li>- Brake monitoring for EN81-20:2014 5.6.7.3</li> </ul> <p><b>Machinery Directive</b></p> <ul style="list-style-type: none"> <li>- EN ISO13849-1: PL-e</li> <li>- EN60204-1: stop category 0</li> <li>- EN61800-5-2: STO SIL3</li> <li>- EN62061: SIL3</li> </ul> <p><b>Low Voltage Directive</b></p> <ul style="list-style-type: none"> <li>- EN61800-5-1: Over voltage category 3</li> </ul> <p><b>EMC Directive</b></p> <ul style="list-style-type: none"> <li>- with external EMC filter EN12015, EN12016, EN 61800-3 +A1, EN 61326-3-1 (Emission): Category 2 (0025 (11kW) or lower) / Category 3 (0032 (15kW) or higher) (Immunity): 2nd Env.</li> </ul> <p><b>Canadian and U.S. standards</b></p> <ul style="list-style-type: none"> <li>- Can/CSA C22.2 No.14-13: Industrial Control Equipment</li> <li>- CSA C22.2 No.274-13: Adjustable speed drives</li> <li>- UL 508 C (3rd Edition): Power Conversion Equipment</li> <li>- According to CSA B44.1-11/ASME A17.5-2014: Elevator and escalator electrical equipment</li> </ul>					
Enclosure (IEC60529)	Main body	IP20					
	Heat sink	IP54					
Cooling method		Fan cooling					

\*1) Rated capacity is calculated by regarding the output rated voltage as 440 VAC.

\*2) Output voltage cannot exceed the power supply voltage.

\*3) These values correspond to the following conditions: carrier frequency is 8 kHz (2 phase modulation) and ambient temperature is 45°C. Select the inverter capacity such that the square average current during operation is not higher than the 80% of the rated current of the inverter.

\*4) Voltage unbalance [%] = (Max.voltage [V] - Min.voltage [V]) / Three-phase average voltage [V] x 6 (IEC61800-3).

\*5) The power supply capacity is 500kVA (ten times the inverter capacity when the inverter capacity exceeds 50kVA), and the value of the power supply impedance is %X = 5%.

\*6) The admissible error of minimum resistance is ±5%.

\*7) Braking time and duty cycle (%ED) are defined by cycle operation at the rated regenerative power.

\*8) Rated current is for 45°C, rated current in brackets corresponds to ambient temperature of 40°C.

\*9) To activate this mode set F81=1. Available in FRN0015LM2C-4E to FRN0032LM2C-4E with ROM version 1500 or later. For additional information refer to INR-SI47-2354-E.

\*10) Only for rescue operation. Do not use during normal operation.



### 3.3 External dimensions

Table 3.2. External dimensions and frame definition.

Power Supply voltage	Type	Frame	W (mm)	H (mm)	D (mm)
3-ph 400 VAC	FRN0010LM2C-4E	1	140,0	260,0	195,0
	FRN0015LM2C-4E				
	FRN0019LM2C-4E				
	FRN0025LM2C-4E				
	FRN0032LM2C-4E	2	160,0	360,0	195,0

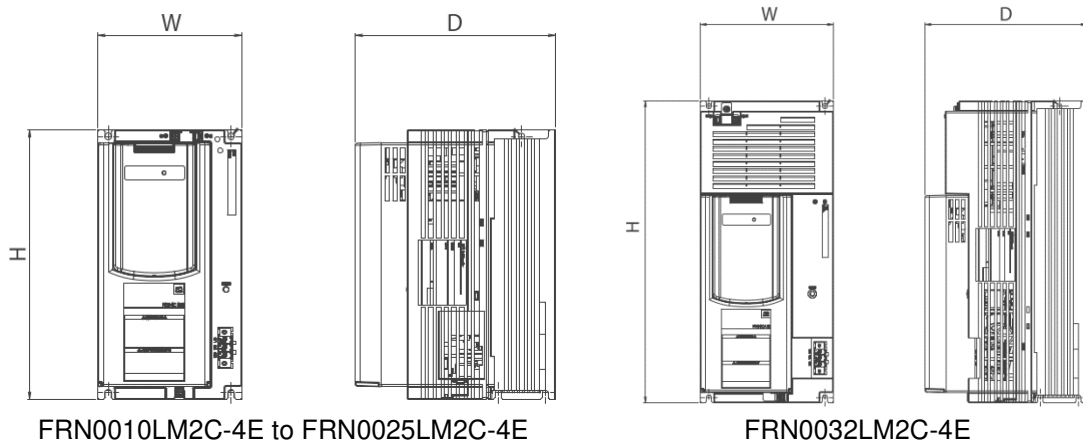

### 4. Removal and attachment of front cover

In order to remove properly front cover, please follow the procedure below figure. In the following description, it is assumed that the inverter has already been installed.

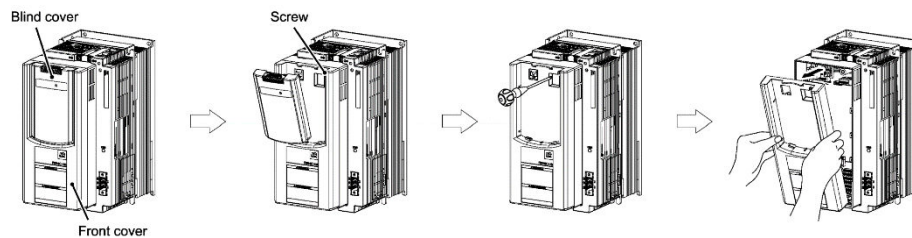

Figure 4.1: Removing front cover step by step (Frame 1 & 2)

## 5. Connections

### 5.1 Power terminals connection

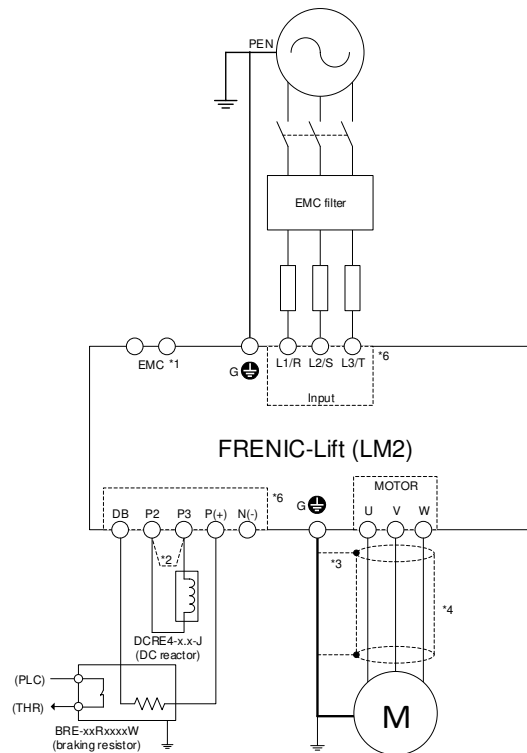

Figure 5.1. Power terminals connection.

Note \*1: Not used.

Note \*2: DC Reactor terminals:

- In case of NOT installing DC Reactor wire a jumper between terminals P2 and P3.

Note \*3: Use the metal plates placed on removable terminals to connect the shield by means of metal cable ties for example.

Note \*4: In case of not installing the two MC between motor and inverter, please follow the procedure explained in "AN-Lift2-0001" document.

All the power terminals, independently of frame, even do not appear on figure 5.1 are listed in table 5.1.

Table 5.1. Power terminals description.

Terminal label	Description of the power terminals
L1/R, L2/S, L3/T	3-phase supply input from mains supply.
U, V, W	3-phase motor connection for induction motors.
U0, V0, W0	Not used.
P2, P3	DC Reactor connection.
24V+, 24V-	Input power terminals for 24 VDC. These terminals have to be used in case of rescue operation by means of batteries to supply control circuit.
DB, P(+)	Connection of external braking resistor.
EMC	Not used.
⊕ G	Terminals for the connection of the inverter enclosure with the protecting earth. 3 terminals available.

⚡ Please connect the screen in both motor and inverter sides. Ensure that the screen is continued also through the main contactors (if used).

⚡ It is recommended to use braking resistors with thermal switch in order to protect the system from failures. Additionally, inverter has a software function to electronically protect the system (For additional information please check parameters F50 to F52).

## 5.2 Control signals connection

In figure 5.2 all control terminals included in the electronic boards are shown. Electronic boards are divided in control board (fixed) and I/O terminals board (removable). I/O terminals board can be easily removed from control board. EN circuit terminals have their own connector which can be removed as well. For additional information about wiring and terminals function refer to below sub chapters.

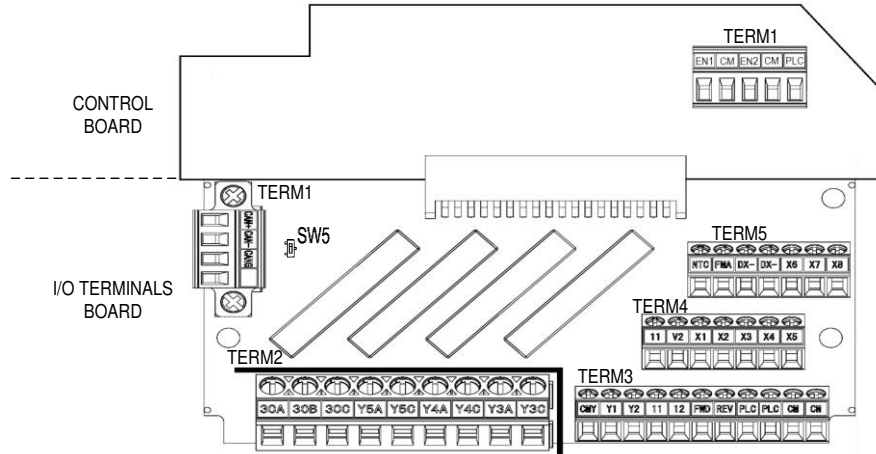

Figure 5.2. Control board and I/O terminals board terminals

All the examples below are based on FRENIC-Lift (LM2C) default setting. For other functions please refer to FRENIC-Lift RM document.

## 5.3 Use of input terminals for speed set point selection

Table 5.2: Binary combination for speed selection

X3 (SS4)	X2 (SS2)	X1 (SS1)	Binary speed coding function	Value	Selected Speed	Speed set point function
0	0	0	L11	0 (000)	Zero speed	C04
0	0	1	L12	1 (001)	Intermediate speed 1	C05
0	1	0	L13	2 (010)	Inspection speed	C06
0	1	1	L14	3 (011)	Creep speed	C07
1	0	0	L15	4 (100)	Intermediate speed 2	C08
1	0	1	L16	5 (101)	Intermediate speed 3	C09
1	1	0	L17	6 (110)	Intermediate speed 4	C10
1	1	1	L18	7 (111)	High speed 1	C11

In case that lift controller signals does not match with selected speed described in table 5.2, signals can be adapted by modifying the setting on parameters L11 to L18. In the example below (table 5.3), lift controller uses X2 and X1 as a High speed and X1 as a Creep speed.

Table 5.3: Example of binary combination for speed selection modification.

SS4 (X3)	SS2 (X2)	SS1 (X1)	Binary speed coding function	Value	Selected Speed	Speed set point function
0	0	0	L11	0 (000)	Zero speed	C04
1	1	1	L12	7 (111)	Intermediate speed 1	C05
0	1	0	L13	2 (010)	Inspection speed	C06
0	0	1	L14	1 (001)	Creep speed	C07
1	0	0	L15	4 (100)	Intermediate speed 2	C08
1	0	1	L16	5 (101)	Intermediate speed 3	C09
1	1	0	L17	6 (110)	Intermediate speed 4	C10
0	1	1	L18	3 (011)	High speed 1	C11

## 5.4 Control terminals description

Control terminals can be classified between digital signals (input and output), analog signals (input and output) and communication ports. Below each type of terminal is described. All inputs and outputs can be freely programmed with any available function. For an easy set up all examples on this guide are referred to default configuration.

### 5.4.1 Analog inputs

Using analog inputs, the motor speed and the torque bias can be set without steps (stageless). Analog command signals can be either voltage or current on terminal [V2]; selection is done by means of slide switch SW4.

Terminal [NTC] can be used to connect a PTC/NTC thermistor for motor overheat protection. Function is disabled in factory setting, for additional information refer to description of parameter H26 in Reference Manual.

### 5.4.2 Digital inputs

Digital inputs can operate either in NPN or PNP logic. The selection of the logic is set on slide switch SW1 located on the control board. Factory setting is PNP (Source) Logic. Description of each input terminal function can be found on table 5.4.

Table 5.4: Description of digital inputs (optocoupled inputs).

Terminal	Function description of the digital inputs
FWD	Clockwise rotation of the motor seen from the shaft side. Depending on the mechanical set up this can be UP or DOWN direction of the car.
REV	Anticlockwise rotation of the motor seen from the shaft side. Depending on the mechanical set up this can be DOWN or UP direction of the car.
CM	Common 0 VDC.
X1 to X3	Digital inputs for speed selection. From binary combination, 7 different speeds can be selected.
X4 to X7	The default setting function of these terminals is not explained on this guide. For additional information refer to Reference Manual.
X8	Configured from factory as "BATRY" for Battery or UPS operation (Rescue operation).
EN1 & EN2	Inverters enable terminals (IGBT drives habilitation). These terminals complies with the STO SIL 3 function described in the standard 61800-5-2, therefore if properly used, these terminals can be used to substitute the two contactors between the inverter and the motor (as described on EN81-20:2014 5.9.2.5.4 d). For additional information regarding STO function, refer to "AN-Lift2-0001" document. Even STO function is not used, the correct usage of these terminals is recommended. An incorrect usage of these terminals can deal to inverter trips (OCx trip) or even to the destruction of it. For additional information, refer to figure 5.5. The logic of these terminals is fixed to SOURCE. It does not depend on SW1 configuration.

On below figures, different input configuration examples are shown. On below images different connection examples using PNP Logic are shown:

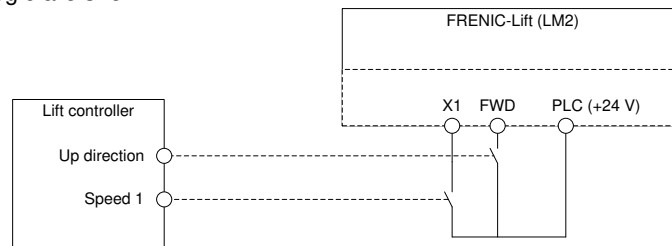

Figure 5.3: Connection using free potential contacts of lift controller.

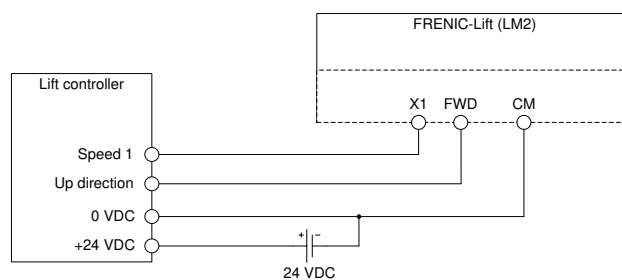

Figure 5.4: Connection using external power supply.

As explained in table 5.4, even STO function is not used, a proper usage of EN terminals is recommended. In figure 5.5 an example of wiring is shown.

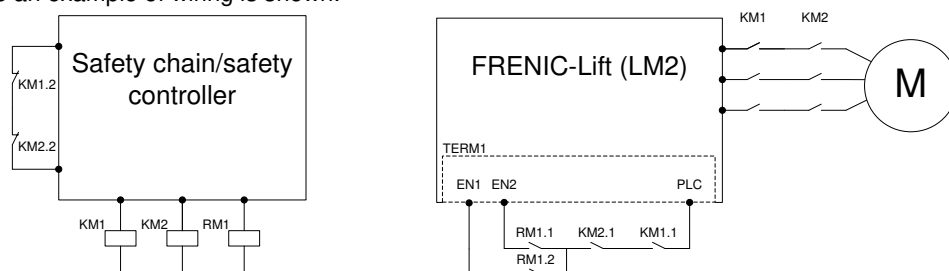

Figure 5.5: Recommended wiring of EN circuit terminals.

Electrical specifications of digital inputs using PNP (Source) Logic is shown in table 5.5.

Table 5.5: Digital inputs electrical specifications.

Item	Status	Range
Voltage	ON	22 to 27 V
	OFF	0 to 2 V
Current	ON	Min. 2.5 mA /Max. 5.0 mA

#### 5.4.3 Relay output

Terminals Y3 (A/C), Y4 (A/C), Y5 (A/C) and 30 (A/B/C) are configured from factory with the functions described in the table 5.6. Other functions can be set using functions from E22 to E30.

Table 5.6: Default setting and specifications of relay outputs.

Terminals	Function description of the relay outputs
30A, 30B and 30C	Inverter in alarm status (ALM). In case of fault, the motor stops and the contact 30C-30A (NO) switches (closes). Contact rating: 250 VAC; 0.5 A / 30 VDC; 0.5A.
Y5A-Y5C	Motor brake control function (BRKS). Contact rating: 250 VAC; 0.5 A / 30 VDC; 0.5A.
Y4A-Y4C	Main MC control function (SW52-2). Contact rating: 250 VAC; 0.5 A / 30 VDC; 0.5A.
Y3A-Y3C	Speed detected function (FDT). Contact rating: 250 VAC; 0.5 A / 30 VDC; 0.5A.

#### 5.4.4 Transistor output

Terminals Y1 and Y2 are configured from factory with the functions described in the table 5.7. Other functions can be set using functions E20 and E21.

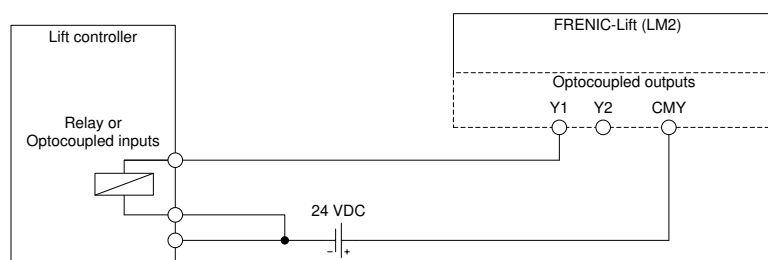

Figure 5.6: Connection using PNP (Source) Logic

Table 5.7: Default setting and specifications of transistor outputs.

Terminal	Function description of the transistor outputs
Y1	Main MC control function (SW52-2).
Y2	Anticipated door opening control (DOPEN).
CMY	Common for transistor outputs

Electrical specification of transistor outputs is shown in table 5.8.

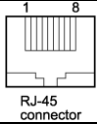
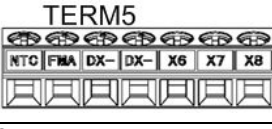

Table 5.8: Output transistors electrical specifications.

Item	Status	Range (Max.)
Voltage	ON	3 V
	OFF	48 V
Operation current	ON	50 mA
Leakage current	OFF	0.1 mA

- ⚡ In case of Figure 5.6 example, the voltage OFF is 24 VDC (Power supply connected to CMY).
- ⚡ Inductive loads should not be connected directly (they should be connected through a relay or optocoupler).

#### 5.4.5 Communication ports

FRENIC-Lift (LM2) has up to three communication ports built-in. CAN bus is accessible by removable terminal TERM1 in I/O terminals board. RS-485 port 1 is accessible by RJ-45. RS-485 port 2 is accessible by I/O terminals board terminals DX+ and DX-.

 RJ-45 connector	 TERM5	
Port 1 (Keypad, Modbus RTU, Loader software, DCP)	Port 2 (Modbus RTU, Loader software, DCP)	Port 3 (CAN bus)

For additional information about communication protocols refer to specific manual.

## 6. Hardware configuration

Up to 5 slide switches can be found in the control and I/O terminals boards. With these switches different configurations can be set. Function of each switch and its possible configurations are shown in table 6.1.

Table 6.1: Configuration of the slide switches

Switch	Slide switches factory setting
SW1	Digital inputs operation mode selection between PNP and NPN (SINK/SOURCE).
SW2	Terminating resistor of RS-485 communications port 1. Port 1 is in RJ-45 connector. (When keypad or converter for FRENIC Loader is used, set SW2 to OFF position). (When DCP or Modbus communication is used, set SW2 to ON position if needed).
SW3	Terminating resistor of RS-485 communications port 2. Port 2 is in I/O terminals board. (When converter for FRENIC Loader is used, set SW3 to OFF position). (When DCP or Modbus communication is used, set SW3 to ON position if needed).
SW4	[V2] terminal function selection between V2 (0 to ±10 VDC) and C1 (4 to 20 mA DC).
SW5	Terminating resistor of CAN communications port. (When CANopen communication is used, set SW5 to ON position if needed).

⚡ By using the PTC input, the cut-off (stopping) function of the inverter does not fulfil EN81-20/50.

Figure 6.1 shows the position of the slide switches in the control and I/O terminals board. It shows as well the default position (factory default) of each switch.

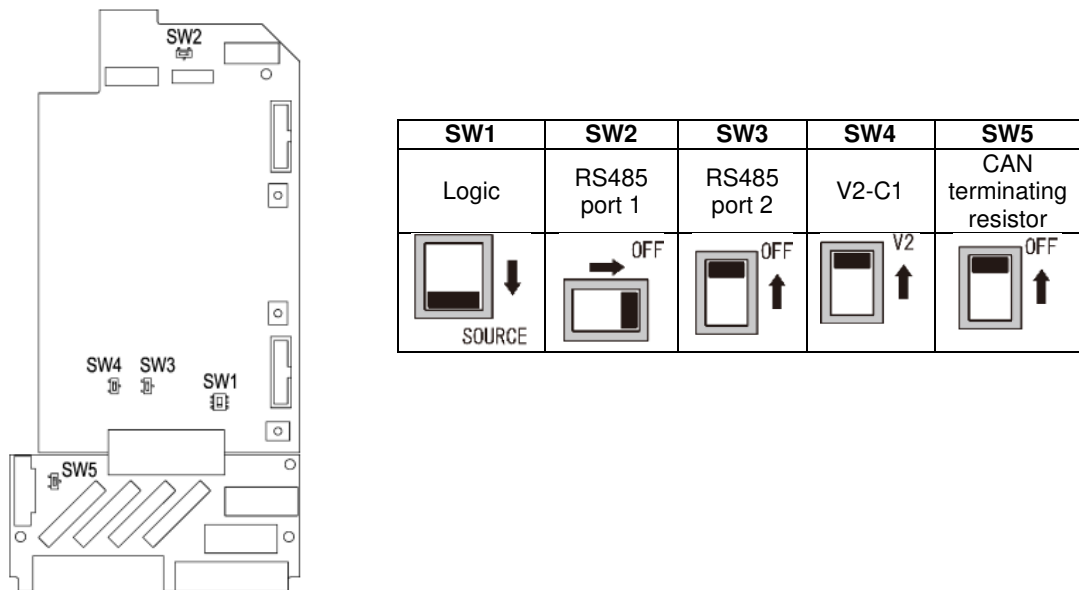

Figure 6.1 Slide switches position and meaning

## 7. Keypad operation

### 7.1 TP-E1U (Basic keypad)

#### 7.1.1 Led monitor, keys and LED indicators on the keypad

As shown on Figure 7.1, the keypad consists of a four-digit LED monitor, six keys, and five LED indicators. The keypad allows you to monitor the running status, specify the function code data, and monitor I/O signal states, maintenance information, and alarm information. The meaning of each part of the keypad is explained on Table 7.1.

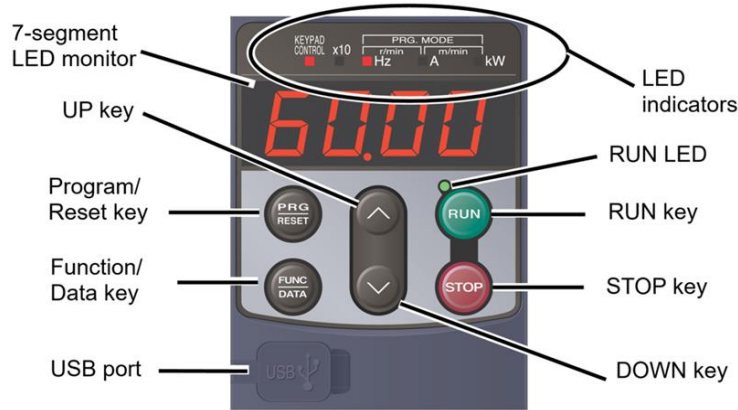

Figure 7.1: Keypad overview

Table 7.1: Overview of Keypad Functions

Item	LED Monitor, Keys, and LED Indicators	Functions
LED Monitor		<p>Four-digit, 7-segment LED monitor which displays the followings according to the operation modes.</p> <ul style="list-style-type: none"> <li>■ In Running mode: Running status information (Monitoring data according to E52 setting).</li> <li>■ In Programming mode: Menu, function codes and their data.</li> <li>■ In Alarm mode: Alarm code, which identifies the alarm factor when the protective function is activated.</li> </ul>
Operation Keys		<p>Program/Reset key which switches the operation modes of the inverter.</p> <ul style="list-style-type: none"> <li>■ In Running mode: Pressing this key switches the inverter to Programming mode.</li> <li>■ In Programming mode: Pressing this key switches the inverter to Running mode.</li> <li>■ In Alarm mode: Pressing this key after removing the alarm factor will switch the inverter to Running mode.</li> </ul>
		<p>Function/Data key which switches the operations you want to do in each mode as follows:</p> <ul style="list-style-type: none"> <li>■ In Running mode: Pressing this key switches the information to be displayed (Monitor data fixed on E52).</li> <li>■ In Programming mode: Pressing this key displays the function code or establishes the data entered with  and  keys.</li> <li>■ In Alarm mode: Pressing this key displays the details of the problem indicated by the alarm code that has come up on the LED monitor.</li> </ul>
		Together with , keypad moves to Programming mode in case of Alarm status.
		UP and DOWN keys. Press these keys to select the setting items and change the function code data displayed on the LED monitor.
LED Indicators	RUN LED	Lights when running with a run command entered by terminal command <b>FWD</b> or <b>REV</b> or through the communications link.
	KEYPAD CONTROL LED	Lights when the inverter is ready to run with a run command.
	Unit LEDs (3 LEDs)	<p>These three LED indicators identify the unit of numeral displayed on the LED monitor in Running mode by combination of lit and unlit states of them. Unit: Hz, A, kW, r/min and m/min.</p> <p>While the inverter is in Programming mode, the LEDs of Hz and kW light. ■ Hz □ A ■ kW</p>
	X10 LED	<p>Lights when the data to display exceeds 9999. When this LED lights, the "displayed value x 10" is the actual value. Example: If the LED monitor displays <i>1234</i> and the x10 LED lights, it means that the actual value is "1,234 × 10 = 12,340."</p>
USB port		The USB port with a Mini-B connector enables the inverter to connect with a PC with an USB cable.

## 7.1.2 Overview of operation modes

TP-E1U keypad can operate in the modes shown in Table 7.2.

Table 7.2. Keypad operation modes

Operation mode	Description
Running mode	The inverter cannot be operated by this keypad. Running mode is only to monitor Run status.
Programming mode	This mode allows you to configure function code data and check a variety of information relating to the inverter status and maintenance.
Alarm mode	If an alarm condition arises, the inverter automatically enters Alarm mode in which you can view the corresponding alarm code* and its related information on the LED monitor. * Alarm code: Indicates the cause of the alarm condition. For details, please refer to Chapter 15.

Figure 7.2 shows the status transition of the inverter between these three operation modes.

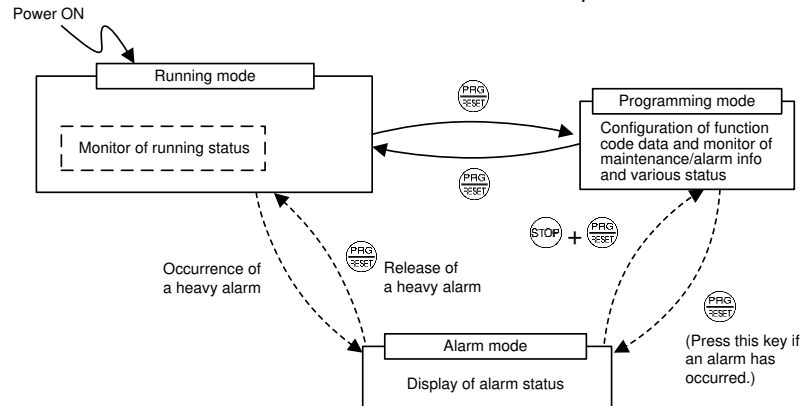

Figure 7.2. Status Transition between Operation Modes



### Simultaneous keying

Simultaneous keying means pressing two keys at the same time. The simultaneous keying operation is expressed by a "+" letter between the keys throughout this manual.

For example, the expression " $\text{STOP} + \text{PRG/RESET}$  keys" stands for pressing the  $\text{PRG/RESET}$  key with the  $\text{STOP}$  key held down.

## 7.1.3 USB connectivity

The keypad has an USB port (Mini-B connector) on its front. To connect an USB cable, open the USB port cover as shown below. The position of the USB port is shown in Figure 7.3.



Figure 7.3. Position of USB port.

For the instructions on how to use the FRENIC Loader 4, refer to the FRENIC Loader Instruction Manual.

## 7.1.4 TP-E1U Menu

Partial menu list can be accessed by pressing  $\text{PRG/RESET}$ . In order to have all menus available please set E52=2.

### 0. Quick Setup (0.Fnc)

Display only basic function codes to customize the inverters operation.

### 1. Data Setting (From 1.F\_\_ to 1.K\_\_)

Selecting each of these function code enables its data to be displayed/changed.

### 2. Data Checking (2.rEP)

Display only function codes that have been changed from their factory defaults. You can refer to or change those function code data.



### 3. Drive Monitoring (3.oPE)

Displays the running information required for maintenance or test running.

Output frequency	3 00
Output current	3 02
Output torque	3 04
Motor speed	3 08

### 4. I/O Checking (4.L\_o)

Display external interface information.

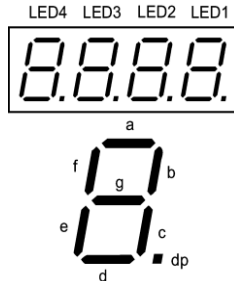

Segments	LED 4	LED 3	LED 2	LED 1
a	30A/B/C	Y1-CMY	X7	FWD
b	---	Y2-CMY	---	REV
c	---	Y3-CMY	---	X1
d	---	Y4-CMY	EN1&2	X2
e	---	Y5A-Y5C	---	X3
f	---	---	(XF)*	X4
g	---	---	(XR)*	X5
dp	---	---	(RST)*	X6

If all terminal input signals are OFF (open), segment "g" on all of LED1 to LED4 will light ("----").

**Note** (XF)\*, (XR)\*, (RST)\* Only for communications.  
This information can be monitored in 4\_00 menu.

### 5. Maintenance Information (5.CHE)

Display maintenance information including cumulative run time.

Cumulative RUN time	5 00
DC link bus voltage	5 01
Max. temperature inside the inverter	5 02
Number of startups	5 08

### 6. Alarm information (6.AL)

Display the recent four alarm codes. You can refer to the running information at the time when the alarm occurred.

Error sub code	6 21
----------------	------

### 7. Data Copying (7.CPY)

Allows you to read or write function code data, as well as verifying it. Customizable logic parameters are copied as well.

#### Example of Function setting

Example of function code data changing procedure is shown in Figure 7.4, in that case F01 is set from 0 to 2.

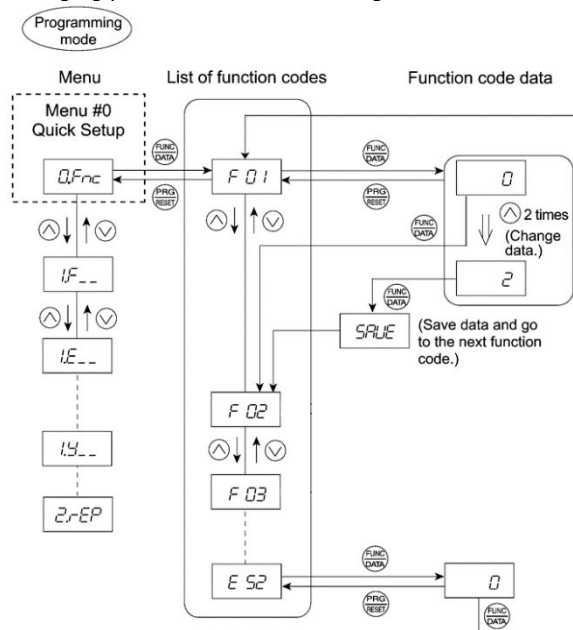

Figure 7.4. Function setting procedure

You can move the cursor when changing function code data by holding down the **FUNC DATA** key for 1 second or longer.

## 7.2 TP-A1-LM2 (Advanced keypad)

### 7.2.1 Keypad keys

Keypad “TP-A1-LM2” allows the user to run and stop the motor locally, monitor the running status, set the function code data, and monitor I/O signal states, maintenance information, and alarm information. Figure 7.5 shows an overview of TP-A1-LM2. Table 7.3 explains the three main areas of the keypad.

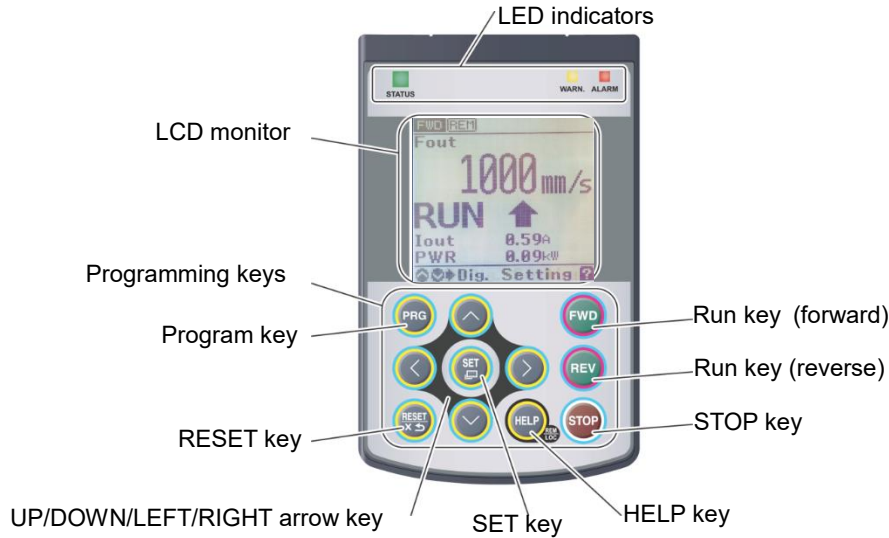

Figure 7.5: Names and Functions of Keypad Components

Table 7.3: Keypad overview.

Keypad item	Specification	Additional information
LED indicators	These indicators show the current running status of the inverter.	Refer to Table 8.4.
LCD monitor	This monitor shows the following various information about the inverter according to the operation modes.	
Keys	These keys are used to perform various inverter operations.	Refer to Table 8.5.

Table 7.4: Indication of LED Indicators.













LED Indicators	Indication	
 STATUS (Green)	Shows the inverter running state.	
	Flashing	No run command input (Inverter stopped)
	ON	Run command input
 WARN. (Yellow)	Shows the warning state (light alarm).	
	OFF	No light alarm has occurred.
	Flashing /ON	A light alarm has occurred. But inverter can continue running.
 ALARM (Red)	Shows the alarm state (heavy alarm).	
	OFF	No heavy alarm has occurred.
	Flashing	A heavy alarm has occurred. Inverter shuts off its output.

Table 7.5: Overview of Keypad Functions.

Keys	Functions
	This key switches the operation modes between Running mode/Alarm mode and Programming mode.
	Reset key which works as follows according to the operation modes. <ul style="list-style-type: none"> <li>■ In Running mode: This key cancels the screen transition.</li> <li>■ In Programming mode: This key discards the settings being configured and cancels the screen transition.</li> <li>■ In Alarm mode: This key resets the alarm states and switches to Programming mode.</li> </ul>
	UP/DOWN key which works as follows according to the operation modes. <ul style="list-style-type: none"> <li>■ In Running mode: These keys switch to the digital reference speed (when local mode).</li> <li>■ In Programming mode: These keys select menu items, change data, and scroll the screen.</li> <li>■ In Alarm mode: These keys display multiple alarms and alarm history.</li> </ul>

Keys	Functions
 / 	These keys move the cursor to the digit of data to be modified, shift the setting item, and switch the screen.
	Set key which works as follows according to the operation modes. <ul style="list-style-type: none"> <li>■ In Running mode: Pressing this key switch to the selection screen of the LCD monitor content.</li> <li>■ In Programming mode: Pressing this key establishes the selected items and data being changed.</li> <li>■ In Alarm mode: Pressing this key switch to the alarm detailed information screen.</li> </ul>
	Pressing this key call up the HELP screen according to the current display state. Holding it down for 2 seconds toggles between the remote and local modes.
	Pressing this key starts running the motor in the forward rotation (when local mode).
	Pressing this key starts running the motor in the reverse rotation (when local mode).
	Pressing this key stops the motor (when local mode).

### 7.2.2 Keypad menus

Table 7.6: Keypad menus organization and its function.

Main Menu	Sub-Menu	Hierarchy indicator	Principal Functions	
0. Quick Setup: Shows only frequently used function codes.				
	—	PRG>0		
1. Start-up: Sets functions for initial settings.				
	1	Language	PRG>1>1	Sets language to be displayed on LCD monitor.
	2	Select application	PRG>1>2	Allows individual initialization of function codes that are grouped by application.
	3	Display settings	PRG>1>3	Selects content to be displayed on LCD screen.
2. Function Code: Setting screens related to function codes, such as setting/copying function code data.				
	1	Set data	PRG>2>1	Allows function code data to be displayed/changed.
	2	Confirm data	PRG>2>2	Allows confirmation of function code settings.
	3	Confirm revised data	PRG>2>3	Allows confirmation of function code changes from factory-default settings.
	4	Copy data	PRG>2>4	Reads, writes and verifies function code data between the inverter and the keypad.
	5	Initialize data	PRG>2>5	Restores function code data values to factory-default settings.
3. INV Information: Allows monitoring of inverter operational status.				
	1	Operation monitor	PRG>3>1	Displays operational information.
	2	I/O checking	PRG>3>2	Displays external interface information.
	3	Maintenance information	PRG>3>3	Displays cumulative run time and other information used during maintenance.
	4	Unit information	PRG>3>4	Allows confirmation of inverter type, serial number and ROM version.
	5	Travel direction counter	PRG>3>5	Allows confirmation and setting of travel direction counter. This function provides the information for replacing wire/rope.
4. Alarm Information: Displays alarm information.				
	1	Alarm history	PRG>4>1	Lists alarm history (newest + 3 previous). In addition, this allows you to view the detail information on the running status at the time when alarm occurred.
5. User Configure: Allows any settings to be made.				
	1	Quick setup selection	PRG>5>1	Allows function codes to be added to or deleted from the "Quick Setup".
6. Tools: Various functions				
	1	Customizable logic monitor	PRG>6>1	Previews status of each step in customizable logic.
	2	Load Factor Measurement	PRG>6>2	Allows measurement of the operational status of the maximum output current and average output current.
	3	Communication Debugging	PRG>6>3	Allows monitoring and setting of function codes for communication (S, M, W, X, Z, etc.)

### 7.2.3 Example of function setting

PRG > 2 > 1

This section explains how to set function code data. The example below shows how to change “F03: Rated speed” from 1450 r/min to 1800 r/min.

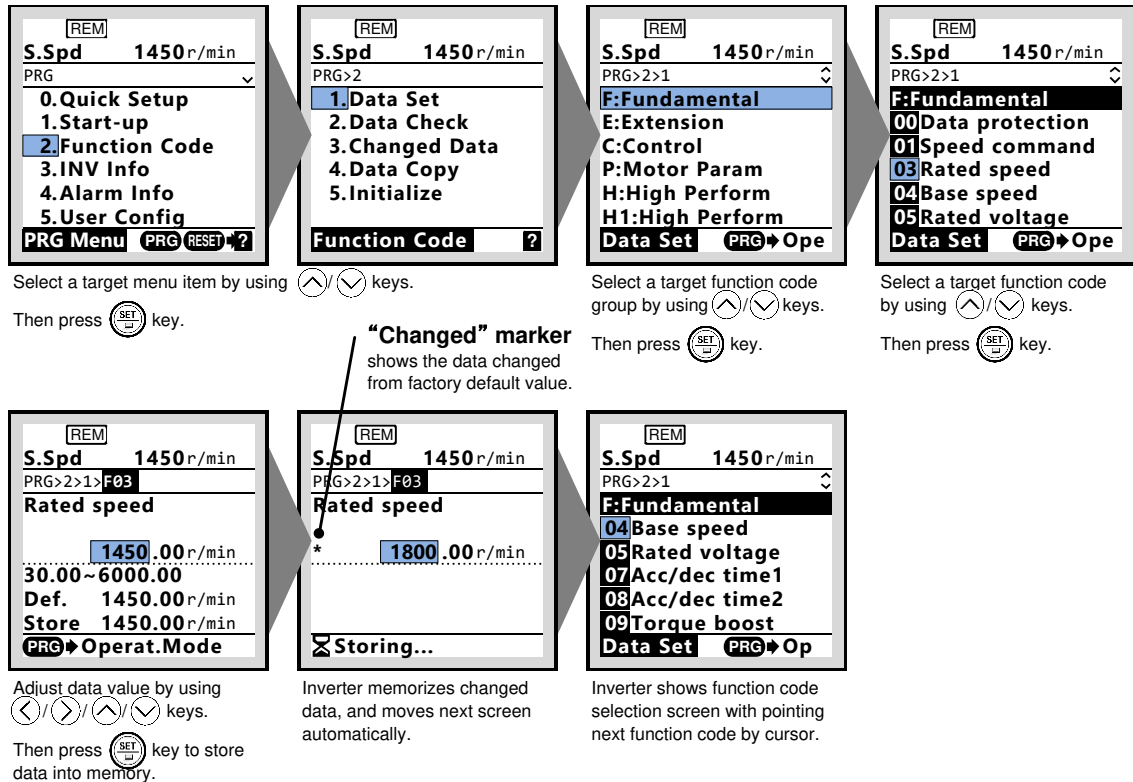

Figure 7.6: Screen transition example for setting a function code.

### 7.2.4 Display language setting

TP-A1-LM2: PRG > 1 > 1

TP-E1U: 1.K > K01

Display language can be selected on sub menu Language of the Menu 1. Start-up. To access the Program menu press PRG key, select the desired menu by using up and down arrow and validate with SET key. Another way is by changing the setting on parameter K01. Table 7.5 shows all available languages and its associated number.

Table 7.5: Available languages.

Language selection	Language
1	English
3	German
4	French
5	Spanish
6	Italian
7	Greek
8	Russian
9	Turkish
10	Czech
11	Polish
13	Swedish
14	Portuguese
15	Dutch
100	User-customized language

## 8. Driving the motor

### 8.1 Inverter initialization

TP-A1-LM2: PRG > 2 > 5

TP-E1U: 1.H > H03

Inverter can be programmed with different pre-settings depending on the application type. Changing the data requires double-key operation (the  key and the  key or the  key and the  key). The types of initialization shown in Table 8.1 are available.

Table 8.1: Initialization types with H03

Initialization type		Function
0	Disable initialization	Does not initialize. Data set by the user is kept.
3	Vector control for IM (open loop)	Initialize all function code data to settings suited for open loop control for IM.

*Default control mode in LM2C is Torque vector control (F42 = 2). V/f control is available as well when F42=3. In V/f control slip compensation (P12) is not active, therefore the stopping level of the lift car might be dependent on the car load.*

### 8.2 Specific setting

Motor parameters, in other words motor name plate, have to be set manually. Table 8.2 shows the basic setting that needs to be set. Parameters has to be set in the same order shown in the table below, otherwise a malfunction may occur.

Table 8.2. Basic setting for induction motors (IM).

Function	Meaning	Factory setting	Comments
F81	230V mode	0	In case of 3ph 230V supply change setting to 1.
P01	Motor poles.	4	Depends on the motor.
F03	Motor's rated speed. Normally F03 is motor speed at nominal lift speed.	1450 rpm	
F04	Motor's synchronous speed. For 4-pole motors (50Hz) is 1500 r/min, for 6-poles motors (50Hz) is 1000 r/min.	1500 rpm	Depends on the motor.
F05	Motor rated voltage.	V	Depends on the motor.
F11	Overload detection level.	A	Set manually same value than P03.
P02	Motor rated power (kW).	kW	Depends on the motor.
P03	Motor rated current.	A	Depends on the motor.

### 8.3 Auto tuning procedure

After inverter initialization and motor parameters setting, an auto tuning has to be performed. Auto tuning will get special data from the motor like no-load current (P06), stator resistance (P07), stator inductance (P08) and slip frequency (P12).

In order to perform an auto tuning follows below step by step procedure:

1. **Please set the functions described in the Table 8.1 and 8.2.**
2. Set function P04 to 3 and press SET.
3. Give RUN command to the inverter from the lift controller (normally INSPECTION mode). Keep the RUN command until inverter indicates that the procedure has been finished. At this point, the main contactors will be closed and current will flow through the motor producing some acoustic noise. This procedure will take some seconds. After this auto tuning procedure is finished.

If during the procedure inverter trips Er7 make sure that setting specified in Table 8.1 and 8.2 is correctly set. Make sure as well of the connection recommended on chapter 5. Connections. If too high no-load current is recognized, try auto tuning mode 2 (P04=2).

After that, please give RUN command from the lift controller (for example in INSPECTION), and check that motor is turning without any problem. Check that the output current has reasonable value. By a reasonable value it is understood below rated current (empty car going down for example).

TP-A1-LM2: PRG > 3 > 2 [6/6]

TP-E1U: 4 17

## 9. Setting the speed profile

The setting of the speed profile includes:

- Travelling speed
- Acceleration and deceleration times (s)
- S curves (%)

For the rated speed, each intermediate speed and creep speed the acceleration, deceleration times and S curves can be set independently. Acceleration and deceleration times are referred to maximum speed (F03), in other words, the value set on the acceleration/deceleration ramp is the time to accelerate/decelerate from 0.00 rpm to F03 (and other way around). The setting of the S curve means the speed change in terms of percentage of the maximum speed (F03) used for the acceleration change.

Table 9.1 shows all acceleration/deceleration times and S curves available. Each box shows the acceleration/deceleration ramp used to accelerate/decelerate from the speed shown in the first column to the speed shown in the first row. Ramp will accelerate when the speed set on the column function code is lower than the speed set on the row function code. STOP is the status after or before removing RUN command (FWD or REV).

Table 9.1: Correspondence of acceleration and deceleration ramps and S-curves.

ACCELERATION & DECELERATION RAMPS (S-CURVES)									
AFTER CHANGE BEFORE CHANGE	STOP	C04	C05	C06	C07	C08	C09	C10	C11
STOP	-/F08 (-/-)	F07 (H57 / H58)	F07 (H57 / H58)	F07 (-/-)	F07 (H57 / H58)	F07 (H57 / H58)	F07 (H57 / H58)	F07 (H57 / H58)	F07 (H57 / H58)
C04	E16 (H59 / H60)	F07 / F08 (-/-)	E10 (L19 / L22)	F07 (-/-)	F07 / F08 (H57 / H58)	F07 (L19 / L20)	F07 (L19 / L20)	E10 (L19 / L22)	E12 (L19 / L24)
C05	E16 (H59 / H60)	E11 (L23 / L28)	F07 / F08 (-/-)	F07 / F08 (-/-)	E11 (L23 / L26)	F07 / F08 (H59 / H60)	F07 / F08 (H59 / H60)	F07 / F08 (H57 / H58)	F07 / F08 (H57 / H58)
C06	E16 (-/-)	F08 (-/-)	F07 / F08 (-/-)	F07 / F08 (-/-)	F07 / F08 (-/-)	F07 / F08 (-/-)	F07 / F08 (-/-)	F07 / F08 (-/-)	F07 / F08 (-/-)
C07	E15 (L27)	E14 (L28)	F07 / F08 (H57 / H58)	F07 / F08 (-/-)	F07 / F08 (-/-)	F07 / F08 (H57 / H58)	F07 / F08 (H57 / H58)	F07 / F08 (H57 / H58)	F07 / F08 (H57 / H58)
C08	E16 (H59 / H60)	F08 (L21 / L28)	F07 / F08 (H57 / H58)	F07 / F08 (-/-)	F08 (L21 / L26)	F07 / F08 (-/-)	F07 / F08 (H57 / H58)	F07 / F08 (H57 / H58)	F07 / F08 (H57 / H58)
C09	E16 (H59 / H60)	F08 (L21 / L28)	F07 / F08 (H57 / H58)	F07 / F08 (-/-)	F08 (L21 / L26)	F07 / F08 (H59 / H60)	F07 / F08 (-/-)	F07 / F08 (H57 / H58)	F07 / F08 (H57 / H58)
C10	E16 (H59 / H60)	E11 (L23 / L28)	F07 / F08 (H59 / H60)	F07 / F08 (-/-)	E11 (L23 / L26)	F07 / F08 (H59 / H60)	E11 (L23 / L26)	F07 / F08 (-/-)	F07 / F08 (H57 / H58)
C11	E16 (H59 / H60)	E13 (L25 / L28)	F07 / F08 (H59 / H60)	F07 / F08 (-/-)	E13 (L25 / L26)	F07 / F08 (H59 / H60)	E13 (L25 / L26)	F07 / F08 (H59 / H60)	F07 / F08 (-/-)

In order to know which ramps and S-curves are used we have to enter in Table 9.1 from the left hand column in the row of the speed that is settled before the change (ex. C08) and look up in the column pointing at the target speed after the change (ex. C09). In the intersection of the row and the column we can find the ramps (ex. F07 / F08) and the S-curves (in brackets, ex. H57/H58) used during the change. In the example the change uses F07 as acceleration ramp or F08 in case of deceleration; for the S-curves H57 is used at the beginning of the speed change (close to C08) and H58 is used at the end of the change (when the speed has reached C09).

On Table 9.2 shows different deceleration distances taking in consideration specific settings on speed, ramps and S curves parameters.

Table 9.2: Guideline of acceleration, deceleration times and deceleration distances for different travelling speeds.

Rated speed	Creep speed	Acc./Dec. Times settings	S curve settings Functions L24, L25, L26	Acc./Dec. Times settings	Deceleration distance
Function C11	Function C07	Function E13		Function E14	
0.6 m/s	0.05 m/s	1.6 s	25%	1.6 s	892 mm
0.8 m/s	0.10 m/s	1.7 s	25%	1.7 s	1193 mm
1.0 m/s	0.10 m/s	1.8 s	25%	1.0 s	1508 mm
1.2 m/s	0.10 m/s	2.0 s	25%	1.0 s	1962 mm
1.6 m/s	0.10 m/s	2.2 s	30%	1.0 s	2995 mm
2.0 m/s	0.15 m/s	2.4 s	30%	0.8 s	4109 mm
2.5 m/s	0.20 m/s	2.6 s	30%	0.7 s	5649 mm

⚡ The deceleration distance and therefore the starting point of the deceleration phase depends on the function settings. The deceleration distance shown in the above table is the distance from the start of the deceleration to the final floor landing position. The time during creep speed has been estimated for 1 s. This time depends on the real application.

- Acceleration/Deceleration distances can be monitor as well on TP-A1-LM2 PRG > 3 > 1 [7/8] and [8/8].
- Factory setting of the speed units is rpm (defined by function C21). To set up all functions correctly the rated speed of the motor must be known. If this speed is NOT known it can be calculated from the formula below:

$$n_{rated} = \frac{19,1 \times v \times r}{D \times i}$$

Where  
 v: rated speed in m/s  
 r: Cabin suspension (1 for 1:1, 2 for 2:1, 4 for 4:1,...)  
 D: Pulley diameter in m  
 i: Gear ratio

## 10.Signal time diagram for open loop (IM)

Figure 10.1 shows a complete time diagram and signals sequence in case of open loop application. It shows a standard travel with a lift controlled by digital inputs with high and creep speed. Only induction motors can be controlled in open loop in a standard lift travel.

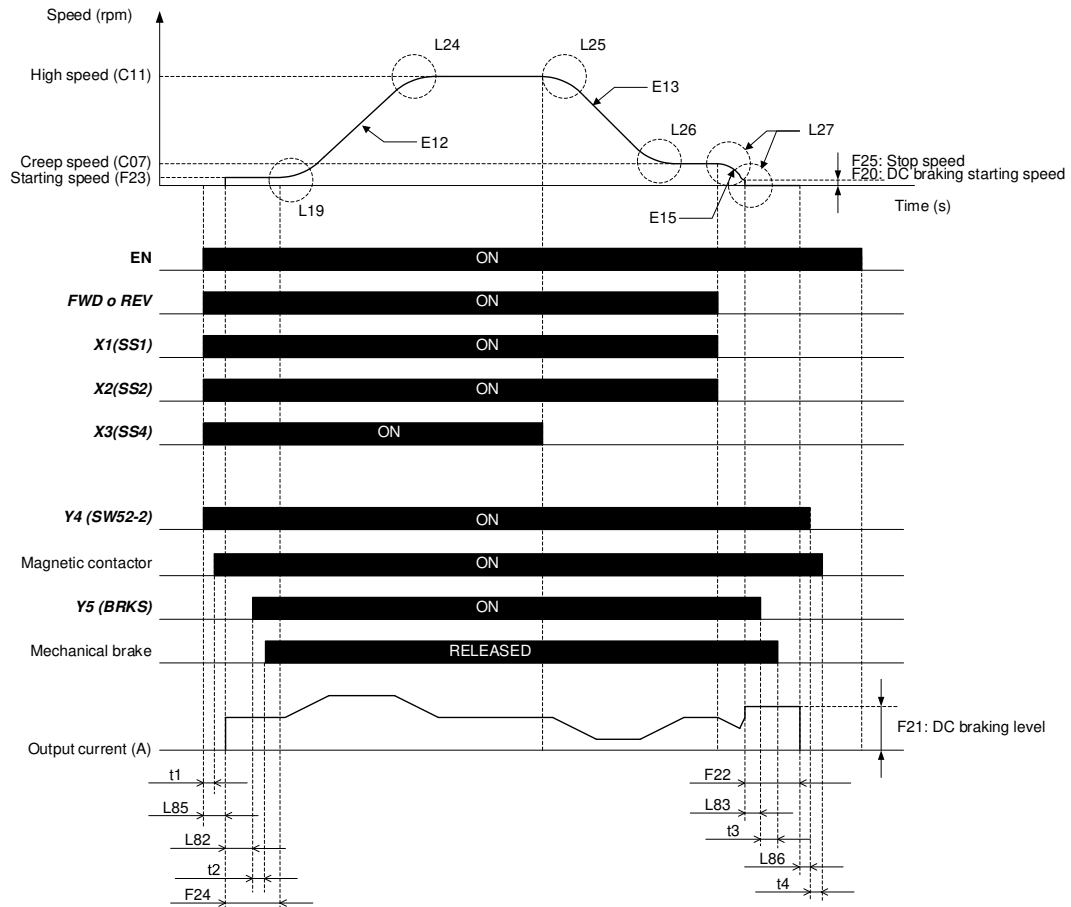

Figure 10.1: Open loop application time and signals sequence diagram.

Sequence description:

### Start:

By activating FWD (UP) or REV (DOWN) terminal and EN1 and EN2 (enable) terminals, t1 and L85 times start to count. At same time high speed is selected by X1, X2 and X3. When timer L85 is elapsed inverter will activate IGBT's gates (voltage at the output ON).

After the completion of time L82 the output of brake control will be activated and the mechanical brake opens (releases) after t2 time elapses (delay time to the reaction of contactors, coil...). After completion of time F24, the speed set point will be used and the lift will start to move accelerating to reach high speed (normal case).

### Stop:

To decelerate to creep speed, the terminal X3 will be deactivated by the lift controller (from the internal settings of the controller).

After reaching the floor level, also creep speed will be deactivated (FWD/REV, X1 and X2 deactivated).

After the deceleration the motor will reach zero speed (F25). At this moment, due to F20 setting, inverter starts to apply DC current (DC braking function). After time L83, the brake output is deactivated (and brake will be applied after t3).

EN signal cannot be removed until no current is flowing from the inverter to the motor. This is when F22 timer is elapsed.

Figure 10.1 is a travel example where brake and main contactor signals are controlled by the inverter. If these signals are controlled by the lift controller, timing might differ.



Speeds, acceleration/deceleration ramps and S curves are based in a specific signals sequence (EN, FWD/REV, X1, X2 and X3). If the signals sequence is different, speed, acceleration/deceleration ramps and S curves might be different.

## 11. Travel optimization

The aim of this test is to achieve the same stopping position independently of the car load. If we can achieve repeatability of stopping, independently of the car load, we only have to reduce (or increase) inverter ramps or move lift magnets (or flags, etc.) in order to stop at floor level.

In this method, we will compare the landing position when the car is half loaded and when the car is empty. When we have half load inside the car, we should have a balanced condition; in this case the slip influences should be almost zero. Choose one floor and wait out of the car. Put **half load** in the car. First call the lift to come to the floor where you are measuring in **down** direction (coming from an upper floor) and measure (note) the distance where the lift has stopped (from the floor level).

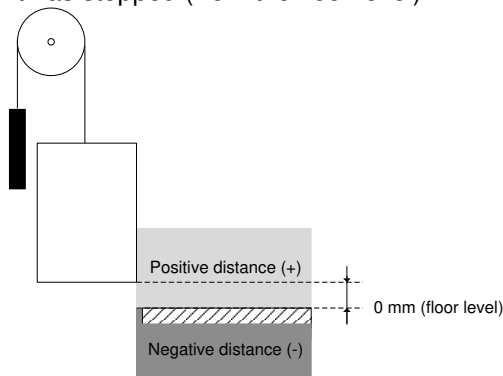

Figure 11.1 Cabin positioning at floor level

If the cabin is above the floor level, the distance is positive (Ex. +4mm); if the cabin is below the floor level, the distance is negative (Ex. -13mm). Repeat the test (still with **half load**) calling the lift to come to the floor where you are waiting in **up** direction (coming from a lower floor) and measure (note) the distance where the lift has stopped (from the floor level).

Remove now the cabin load (**empty cabin**) and measure the stopping position when the cabin is going **down** (coming from upper floor). Doing so, we are checking the slip in driving condition. Compare the position with the one measured with **half load**:

- If the cabin landing position is higher without load than with half load it means that the slip is not enough. We need to give more slip when the cabin is empty (with more slip the lift will go faster than without load in driving condition); in this case increase P09 (slip compensation driving gain) by 10% and measure again.
- If the cabin landing position is higher with half load than without load it means that the slip is too much. We need to give less slip when the cabin is empty (with less slip the lift will go slower without load in driving condition); in this case decrease P09 (slip compensation driving gain) by 10% and measure again.
- If the cabin landing position is the same with half load and without load, there is no need to change slip compensation driving gains. Slip frequency is correctly adjusted in driving condition.

Measure the stopping position when the cabin is going **up** (coming from a lower floor). Doing so, we are checking the slip in braking condition. Compare the position with the one measured with **half load**:

- If the cabin landing position is higher without load than with half load it means that the slip is not enough. We need to give more slip when the cabin is empty (with more slip the lift will go slower without load in braking condition); in this case increase P10 (slip compensation braking gain) by 10% and measure again.
- If the cabin landing position is higher with half load than without load it means that the slip is too much. We need to give less slip when the cabin is empty (with less slip the lift will go faster without load in braking condition); in this case decrease P10 (slip compensation braking gain) by 10% and measure again.



- If the stop distance is the same with half load and without load, there is no need to change slip compensation braking gains. Slip frequency is correctly adjusted in braking condition.

## 12.Lift fine tuning (troubleshooting)

The typical problems have been divided in three different zones: starting, travel and stopping. Figure 12.1 shows a standard lift travel divided in the three areas.

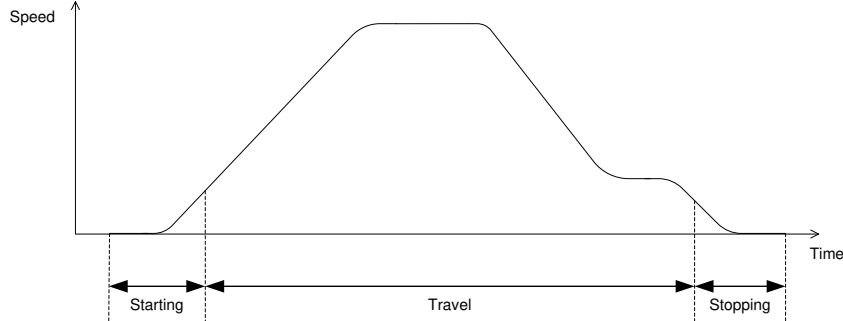

Figure 12.1. Standard lift travel divided in three zones

TROUBLESHOOTING (Starting)		
	CAUSE	ACTION
ROLLBACK	Insufficient starting frequency	Increase <b>F23</b> Max. $F23=1.0$ Hz
	Early brake opening	Increase <b>L82</b> Max. $L82=F24 - \text{Brake reaction time}$
	Insufficient torque	Increase <b>P06</b> $P06=30\sim70\%$ of $P03$
Increase <b>F09</b> Max. $F09=5.0\%$		
	CAUSE	ACTION
HIT AT STARTING	Too high starting frequency	Reduce <b>F23</b> Min. $F23=0.1$ Hz
	Late brake opening	Reduce <b>L82</b> Min. $L82=0.20$ s
		Increase <b>F24</b> Max. $F24=1.5$ s
	Too high torque	Reduce <b>P06</b> $P06=30\sim70\%$ of $P03$
Not related to inverters setting	Check brake operation Check guides (oil, alignment, etc.) Check car fixation (shoes)	

TROUBLESHOOTING (Travel)		
	CAUSE	ACTION
VIBRATION AT CONSTANT SPEED	Too high torque	Decrease <b>P06</b> $P06=30\sim70\%$ of $P03$
	HIGH speed too fast	Reduce HIGH speed (i.e. <b>C11</b> ) Set motors rated speed instead of motor synchronous speed
	Not related to inverters setting	Check guides (oil, alignment, etc.) Check car fixation (shoes) Check motor connection ( $\Delta$ or $\lambda$ ) Check motor gearbox
	CAUSE	ACTION
UNDERSHOOT FROM HIGH SPEED TO CREEP SPEED	Slip frequency too high	Reduce <b>P12</b> Min. $P12=0.1$ Hz
	Deceleration too fast (NOTE: Control that creep speed is kept)	Increase deceleration ramp (i.e. <b>E13</b> ) Max. $E10-E16, F07-F08=2.00$ s
		Increase 2nd S-curve at deceleration (i.e. <b>L25</b> ) Max. $L19-L28, H57-H60=50$ %
Insufficient torque	Increase <b>P06</b> $P06=30\sim70\%$ of $P03$	
	Increase <b>F09</b> Max. $F09=5.0\%$	

TROUBLESHOOTING (Stopping)		
	CAUSE	ACTION
HIT AT STOPPING	Early brake closing	Increase <b>L83</b> <i>Max. L83=F22 - Brake reaction time</i>
	DC brake reaction too strong	Reduce <b>F21</b> <i>Min. F21=50%</i>
	Deceleration ramp too fast	Increase deceleration ramp (i.e. <b>E15</b> ) <i>The maximum value depends on the lift magnets</i>
	Not related to inverters setting	Check security chain Check brake operation
ROLLBACK	Late brake closing	Reduce <b>L83</b>
	DC brake reaction too soft	Increase <b>F21</b> <i>Max. F21=90%</i> Check F22≠0.00s
	Insufficient torque	Increase <b>P06</b> <i>P06= 30~70% of P03</i>
		Increase <b>F09</b> <i>Max. F09=5.0 %</i>
Not related to inverters setting	Check security chain operation (EN signal) Check brake operation	
LANDING ACCURACY (STOPPING DEPENDING ON THE LOAD)		
	Incorrect slip frequency	Perform Auto tuning ( <b>P04=2</b> ) Calculate slip frequency manually $P12 = \frac{(\text{Synchronous\_speed}(rpm) - \text{Rated\_speed}(rpm)) \times \text{Nom\_Frequency}}{\text{Synchronous\_speed}(rpm)}$
		Increase <b>P06</b> <i>P06=30~70% of P03</i>
	Different landing accuracy (braking, driving)	Stopping too early (driving mode): Increase P09 Stopping too late (driving mode): Decrease P09

### 13. Alarm messages

Alarm message Displayed	Description	Possible causes
OC1 OC2 OC3	Instantaneous overcurrent OC1= Overload during acceleration OC2= Overload during deceleration OC3= Overload during constant speed	Check if the motor used in the application has been selected properly. Check if the inverter used in the application has been selected properly. Check if brake opens.
OV1 OV2 OV3	Overvoltage in inverter DC link: OV1= Overvoltage during acceleration OV2= Overvoltage during deceleration OV3= Overvoltage during constant speed	Braking resistor not connected or defective. Counterweight not counterbalanced. Deceleration time too short. Check connection. Check mains connection.
LV	Undervoltage in inverter DC link	Supply voltage too low. Mains supply failure. Acceleration too fast. Load too high. Check connection of the input signal.
Lin*	Input phase loss	Check inverters input protections. Check input connections.
OPL*	Output phase loss	Misconnection on inverters side. Misconnection on motors side. Misconnection on main contactors.
OH1	Heat sink overheat	Inverter fan defective. Ambient temperature too high.
OH2	External Alarm	Digital input programmed with value 9 ( <b>THR</b> ) is not active.
OH3	Inverter internal overheat	Check temperature inside electrical cabinet.
OH4	Motor protection (PTC/NTC thermistor)	Motor fan too small. Ambient temperature too high. Check setting of H26 and H27.

Alarm message Displayed	Description	Possible causes
OH6	Charging resistor overheat	The temperature of the charging resistor inside the inverter has exceeded the allowed limit. Reduce number of Power ON/OFF.
DBH	Braking resistor overheat (Electronic protection)	The temperature of the braking resistor has exceeded the allowable value (power too small). Check setting on F50, F51, F52.
OL1	Overload of motor 1	Check brake. Motor, car or counterweight blocked. Inverter at current limit, possibly too small. Check functions F10~F12.
OLU	Inverter overload	Over temperature in IGBT. Failure in the cooling system. Switching frequency (function F26) too high. Car load too high.
DBA	Braking transistor broken	Detection of an abnormality in the brake transistor.
EF	Ground fault	Zero-phase current caused by ground fault in the output circuit has exceeded the allowable limit.
Er1	Memory error	An error has occurred when writing data to the inverter memory.
Er2	Keypad communication error	A communication error has occurred between the keypad and the inverter.
Er3	CPU error	Failure in the inverter CPU.
Er6	Operation error	Check function L11-L18. Repeated value. Check brake signal status (BRKE). Check MC signal status (CS-MC). Check function L84. Check function L80, L82, L83. Error on brake monitoring (EN81-20).
Er7	Error during Auto Tuning	RUN command removed before finishing the process. Enable input interrupted.
Er8 ErP	RS 485 Communications error (Er8: RS-485 port 1, ErP: port 2)	Cable is interrupted. High noise level.
ErF	Data saving error during undervoltage	Undervoltage is detected (LV) while inverter was saving data.
ErH	Option card hardware error	Option card not correctly installed. Inverter software version not compatible with option card.
Ert	CAN bus communication error	CAN bus disconnected from the inverter. Electrical noise, connect cable shield. Terminating resistor not connected.
bbE	Brake status monitoring according to EN81-20.	Brake state differs from expected. For additional information, please contact Fuji Electric.
tCA	Reaching maximum number of trip counter	The number of trip direction changes has reached the pre-set level. Remove lift ropes/belt and install new ones.
nrb	NTC wire break error	Detected a wire break in the NTC thermistor detection circuit.
ECL	Customizable logic error	A customizable logic configuration error has caused an alarm.
Eo	EN1, EN2 terminals chattering	Detected collision between ENOFF output and EN1/EN2 input terminals.
ECF	EN1 and EN2 terminals circuit error	The inverter detects an error on the enable terminals circuit, and stops itself. Check if the error can be reset by switching OFF and ON. If yes, make sure EN1 and EN2 signals come at same time.

\* These alarms can change enable/disable by a function code.

## CONTACT INFORMATION

Fuji Electric Europe Headquarters

### **Fuji Electric Europe GmbH**

Goethering 58  
63067 Offenbach am Main  
Germany  
Tel.: +49 69 669029 0  
Fax: +49 69 669029 59  
info.inverter@fujielectric-europe.com  
www.fujielectric-europe.com

### **Switzerland**

Fuji Electric Europe GmbH, Swiss Branch  
RietlistraÙe 5  
9403 Goldach  
Tel.: +41 71 858 29 49  
Fax: +41 71 858 29 40  
info.swiss@fujielectric-europe.com  
www.fujielectric-europe.com

### **Spain**

Fuji Electric Europe GmbH, Sucursal en EspaÙa  
Carrer dels Paletes 8, Edifici B, Planta 1, Oficina B  
Parc Tecnològic del Vallès  
08290 Cerdanyola del Vallès (Barcelona)  
Tel.: +34 93 58 24 333  
Fax: +34 93 58 24 344  
info.spain@fujielectric-europe.com  
www.fujielectric-europe.com

### **France**

Fuji Electric Europe GmbH, Succursale France  
265 Rue Denis Papin  
38090 Villefontaine  
Tel.: +33 4 74 90 91 24  
Fax: +33 4 74 90 91 75  
info.france@fujielectric-europe.com  
www.fujielectric-europe.com

### **Italy**

Fuji Electric Europe GmbH, Filiale Italiana  
Via Rizzotto 46  
41126 Modena (MO)  
Tel.: +39 059 47 34 266  
Fax: +39 059 47 34 294  
info.italy@fujielectric-europe.com  
www.fujielectric-europe.com

### **United Kingdom**

Fuji Electric Europe GmbH, UK Branch  
Bedford i-Lab  
Stannard Way  
Priory Business Park  
Bedford MK44 3RZ  
Tel.: +44 1234 834 768  
info.uk@fujielectric-europe.com  
www.fujielectric-europe.com

Subject to change without prior notice